

高亮度薄型背光光源

藉由穿透物體的光線，可輕易擷取物體的形狀。透過這些側面影像，連透明物體的檢測也可輕易實現

可客製化各式尺寸及配件

薄化及輕重量設計，容易安裝到任何需要的位置

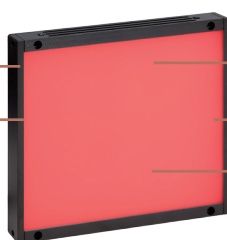

新型LED採用，亮度更高

尺寸樣式最豐富

絕佳散熱設計，壽命更長

外觀尺寸量測

背光模組可將複雜的輪廓變成清晰的側面影像，輕易進行形狀和尺寸量測及瑕疵檢測



正向光源

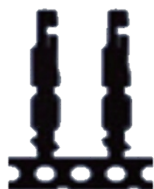

背光

採用光學級擴散板

有效提高取像銳利度，獲得更精細的成成品質
光學及擴散板，提高均勻性
不僅亮度為業界最高，更有效降低整體發熱溫度
表面特殊鍍層，有效消除反光



舊款

新款

金屬基板散熱設計，壽命更長

熱分析模擬技術，搭配先進的導熱基材，達到亮度業界最高，發熱度業界最低的產品

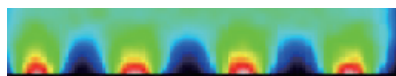

鎖固最便利

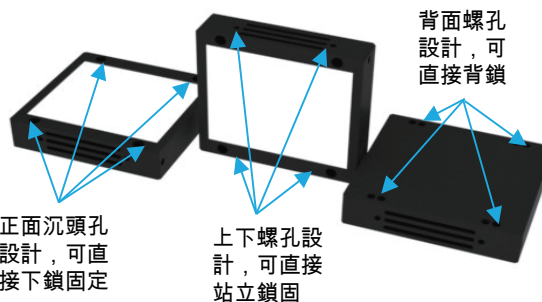

高亮度薄型背光光源 / 背光燈箱 規格表 Product Lineup Table

Dimension	Model 型號		Color 顏色		Power 額定電流	
1	TH2727-G/B/W/UV	TH2727-IR/R	●●●●	●●	0.2A/24V	0.2A/12V
2	TH3013-G/B/W/UV	TH3013-IR/R	●●●●	●●	0.06A/24V	0.06A/16V
3	TH6151-G/B/W/UV	TH6151-IR/R	●●●●	●●	0.36A/24V	0.36A/12V
4	TH8686-G/B/W/UV	TH8686-IR/R	●●●●	●●	0.6A/24V	0.6A/12V
5	TH9898-G/B/W/UV	TH9898-IR/R	●●●●	●●	0.8A/24V	0.8A/12V
6	TH11694-G/B/W/UV	TH11694-IR/R	●●●●	●●	1A/24V	1A/12V
7	TH12151-G/B/W/UV	TH12151-IR/R	●●●●	●●	1.5A/24V	1.5A/12V
8	TH121101-G/B/W/UV	TH121101-IR/R	●●●●	●●	1A/24V	1A/12V
9	TH151121-G/B/W/UV	TH151121-IR/R	●●●●	●●	0.72A/24V	0.72A/12V
10	TH180100-G/B/W/UV	TH180100-IR/R	●●●●	●●	1.5A/24V	1.5A/12V
11	TH181151-G/B/W/UV	TH181151-IR/R	●●●●	●●	2A/24V	2A/12V
12	TH198198-G/B/W/UV	TH198198-IR/R	●●●●	●●	1.5A/24V	1.5A/12V
13	TH201121-G/B/W/UV	TH201121-IR/R	●●●●	●●	2.5A/24V	2.5A/12V
14	TH201181-G/B/W/UV	TH201181-IR/R	●●●●	●●	3.5A/24V	3.5A/12V
15	TH241201-G/B/W/UV	TH241201-IR/R	●●●●	●●	4A/24V	4A/12V
16	TH292292-G/B/W/UV	TH292292-IR/R	●●●●	●●	2A/24V	2A/12V
17	TH330330-G/B/W/UV	TH330330-IR/R	●●●●	●●	2A/32V	2A/24V
18	TH561265-G/B/W/UV	TH561265-IR/R	●●●●	●●	4A/24V	4A/12V
19	THR109-G/B/W/UV	BW IR/R	●●●●	●●	1.4A/12V	0.7A/12V 1.4A/12V
20	THR140-G/B/W/UV	BW IR/R	●●●●	●●	1.5A/12V	1A/12V 1.5A/12V
21	BL141131-G/B/W/UV	BL141131-IR/R	●●●●	●●	1A/24V	1A/24V
22	BL250240-G/B/W/UV	BL250240-IR/R	●●●●	●●	1.5A/24V	1.5A/24V
23	BL281241-G/B/W/UV	BL281241-IR/R	●●●●	●●	2A/24V	2A/24V
24	BL300300-G/B/W/UV	BL300300-IR/R	●●●●	●●	2.5A/24V	2.5A/12V
25	BL384280-G/B/W/UV	BL384280-IR/R	●●●●	●●	3.3A/24V	3.3A/24V
26	BL400400-G/B/W/UV	BL400400-IR/R	●●●●	●●	1.5A/24V	1.5A/12V
27	BL420400-G/B/W/UV	BL420400-IR/R	●●●●	●●	2.5A/24V	2.5A/12V
28	BL470370-G/B/W/UV	BL470370-IR/R	●●●●	●●	2.6A/24V	2.6A/24V
29	BL480400-G/B/W/UV	BL480400-IR/R	●●●●	●●	3A/24V	3A/12V
30	BL550440-G/B/W/UV	BL550440-IR/R	●●●●	●●	4A/24V	4A/12V
31	BL640536-G/B/W/UV	BL640536-IR/R	●●●●	●●	9A/24V	5A/24V
32	BL740470-G/B/W/UV	BL740470-IR/R	●●●●	●●	5.2A/24V	7A/24V
33	BL940740-G/B/W/UV	BL940740-IR/R	●●●●	●●	10.5A/24V	9A/24V
34	BL13401280-G/B/W/UV	BL13401280-IR/R	●●●●	●●	20A/24V	10A/24V
35	DBS180150-G/B/W/UV	DBS180150-IR/R	●●●●	●●	1A/24V	1A/12V

尺寸圖 Dimension (mm)

1. 出線長度 300mm 2. 標示的孔位為固定孔 3. ES(Emitting surface): 發光面

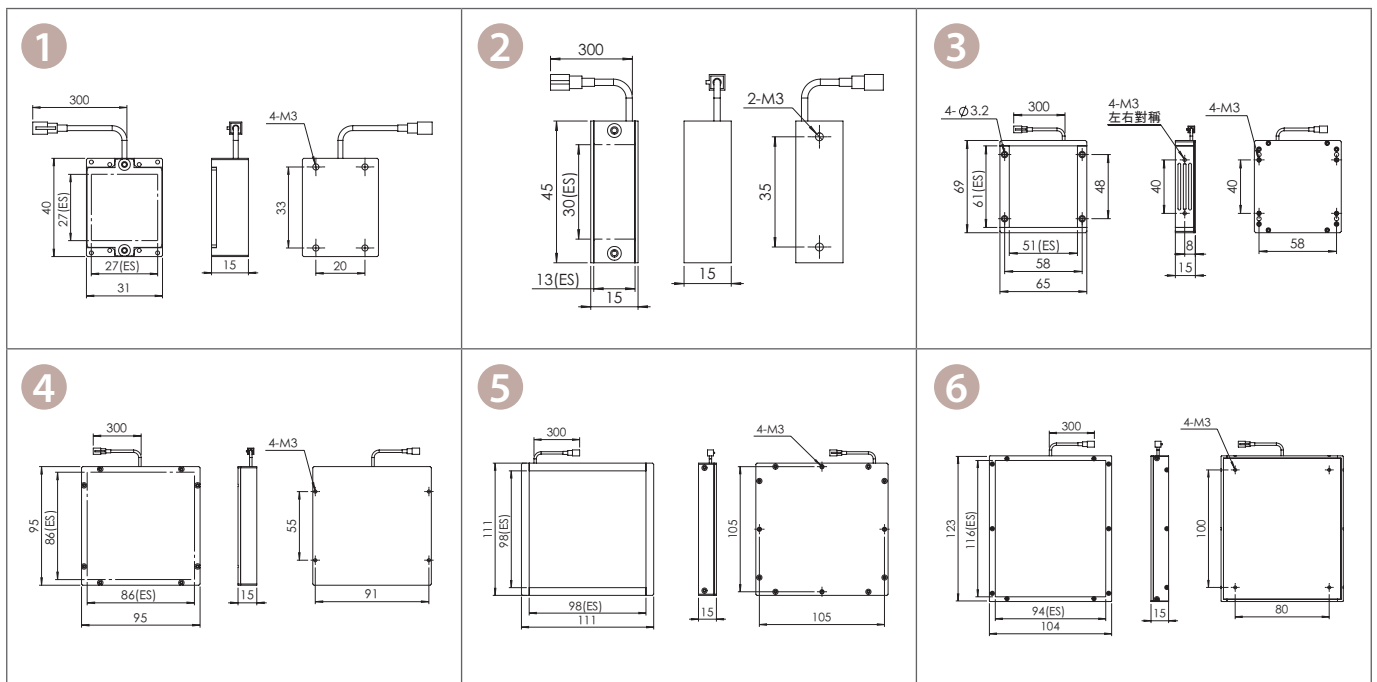

尺寸圖 Dimension (mm)

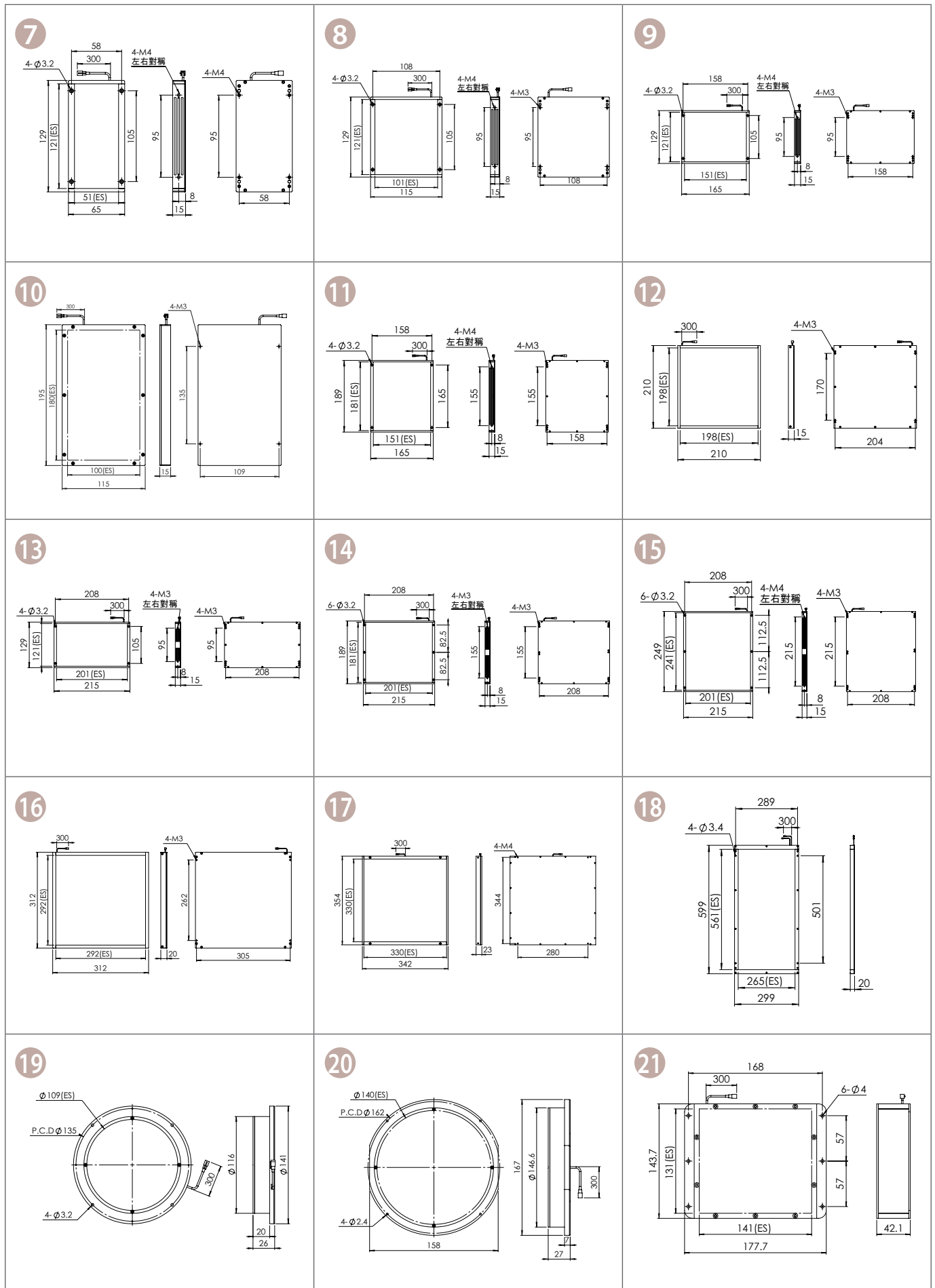

尺寸圖 Dimension (mm)

